

Pro Renfort

Winter 2022



Last Updated: 05/20/2022

LED HEADLAMPS



Meets DOT & SAE Standards

NOTE: Product comes as a pair (left & right)



LWP1330-2K

(In Pair)

High Beam: 3600 Lumens with 1700 ft Penetration

Low Beam: 1800 Lumens with 860 ft Penetration

Functions: High Beam / Low Beam / Turn Signal / Park

Sealed Deutsch Connector (both female & male mating)

10V - 30V EMC
IP68 RoHS

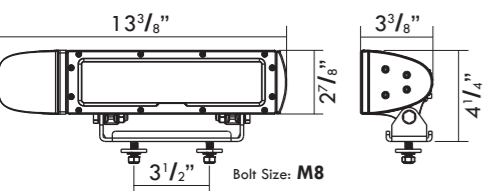

Heavy Duty Double Bolt Mount

NOTE: Product comes with 1x Turn Signal that can be mounted on the left, right or top of the main headlight

ONLY one Turn Signal Light can be used



LWP6800H

(Single Lamp)

High Beam: 3600 Lumens with 1800 ft Penetration

Low Beam: 1800 Lumens with 1000 ft Penetration

Functions: High Beam / Low Beam / Turn Signal / Park

Sealed Deutsch Connector (both female & male mating)

10V - 30V EMC
IP68 RoHS

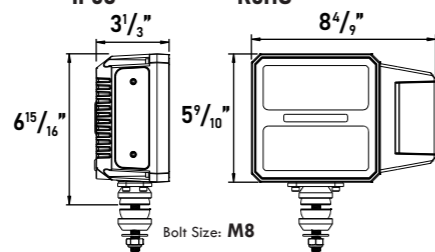

Bottom Mount or Rear Mount

NOTE: Product comes with 1x Turn Signal that can be mounted on the left, right or top of the main headlight

ONLY one Turn Signal Light can be used



LWP6600S

(Single Lamp)

High Beam: 3600 Lumens with 1600 ft Penetration

Low Beam: 1800 Lumens with 980 ft Penetration

Functions: High Beam / Low Beam / Turn Signal / Park

Deutsch Connector

12V - 30V EMC
IP68 9" RoHS

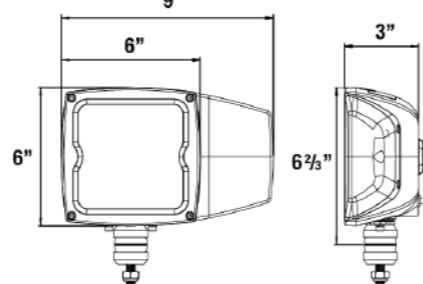

Bottom Mount or Rear Mount

SNOWPLOW PACKAGE

E-71/72 Amber/Blue Plug & Go Package

- Amber/Blue Lamps with 6-Pin Male Connector to plug in mating female connector on the harness set
- Keeps connections organized, clean and free from debris
- Easy installation
- 6-Pin Sealed Connectors

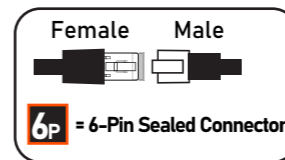

E-7117AB-6

(w/ 6-Pin Male Connector)

108 x 1W LED
17.5" L x 7.25" W x 2.63" H
Surface Mount with Brackets
12V - 24V EMC

E-723AB-6

(w/ 6-Pin Male Connector)

16 x 1W LED
3.38" H x 6.63" Base Dia.
Surface Mount

12V - 24V EMC



Conspicuity Checkerboard - Adhesive Back

size: 70.86" L x 35.43" H



E-F6130
(Amber/Black)

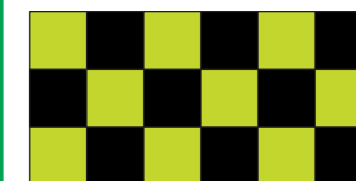

E-F6136
(Lime Green/Black)

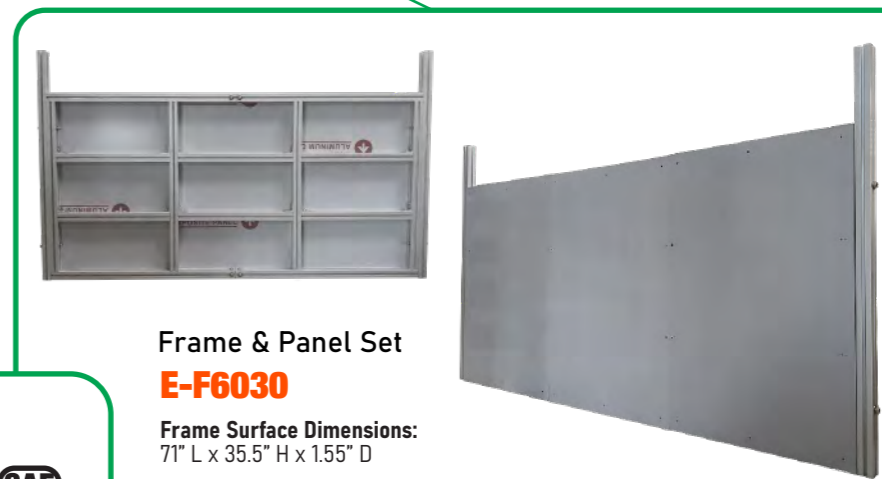
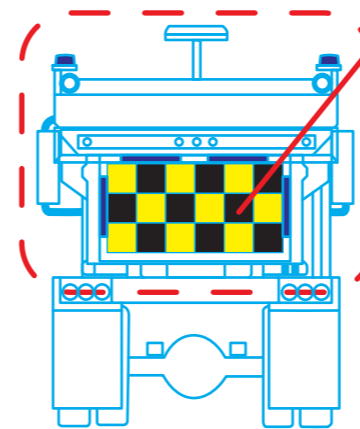

Frame & Panel Set

E-F6030

Frame Surface Dimensions:
71" L x 35.5" H x 1.55" D

E-7224AB-6

(w/ 6-Pin Male Connector)

2x Amber Module || 2x Blue Module
25" L x 1.5" H x 2" D
Bottom or Rear Mount

12V - 24V EMC

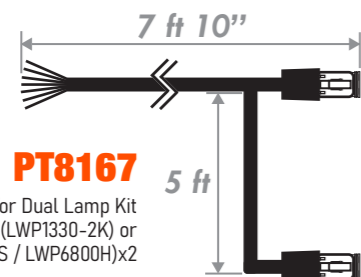
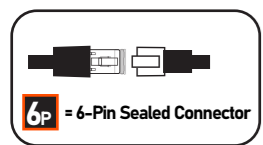

PT8167

"Y" Harness for Dual Lamp Kit for use with (LWP1330-2K) or (LWP6600S / LWP6800H)x2

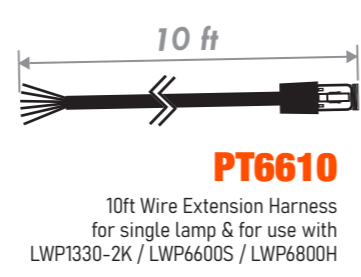

PT6610

10ft Wire Extension Harness for single lamp & for use with LWP1330-2K / LWP6600S / LWP6800H

SNOWPLOW PACKAGE

E-71/72 Amber/Blue Plug & Go Package

Drawing is not a direct representation of installation method & should only be used as an illustration.

Part No.
E-723AB-6 (Qty: 2)



Part No.
PT8604

Part No.
PT8602

Part No.
E-7117AB-6 (Qty: 1)



Part No.
F-S9810 / F-S9820 (Qty: 1)

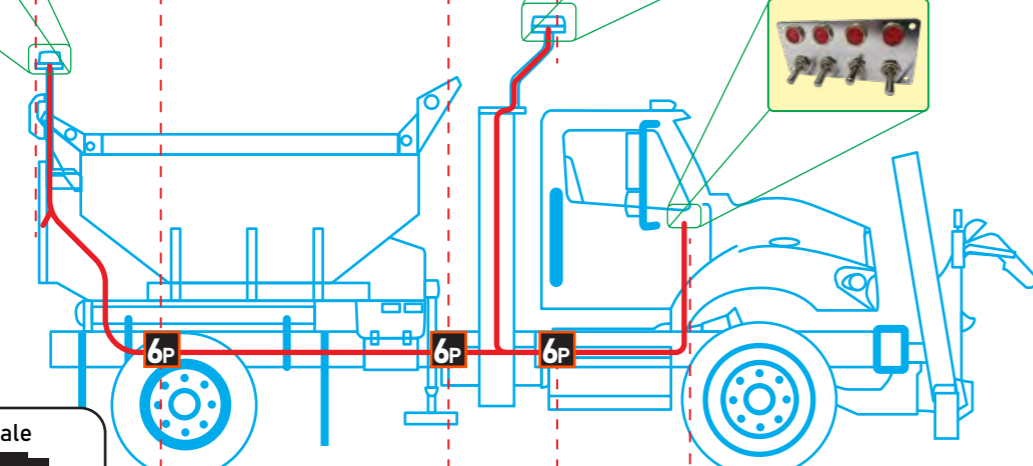
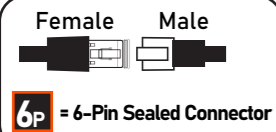

Part No.
PT8603
(10ft or 20ft or 30ft)

Part No.
PT8601

Set-up per TAC Guidelines

Set-up per TAC Guidelines

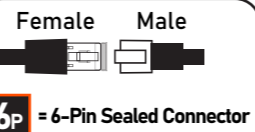

Part No.
PT8604

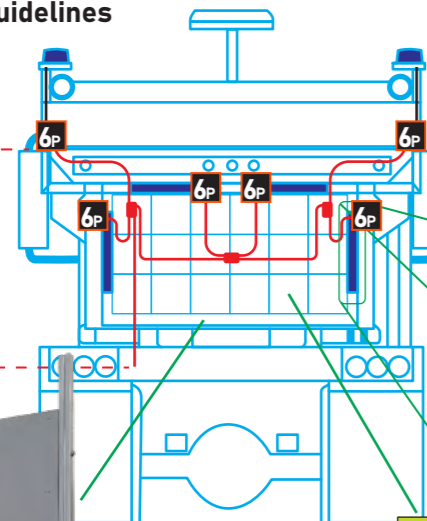

Part No.
E-7224AB-6 (Qty: 4)

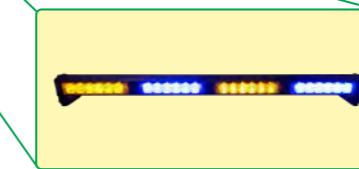

Part No.
E-F6030 (Qty: 1)



Part No.
E-F6130 or E-F6136 (Qty: 1)

SNOWPLOW PACKAGE

E-71/72 Amber/Blue Plug & Go Package

PT8601



PT8602

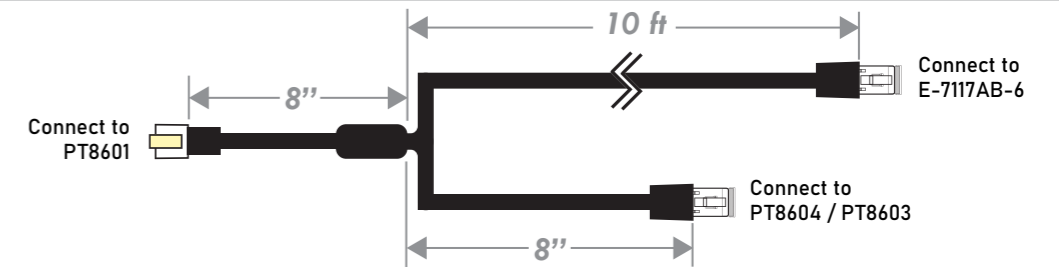

PT8603-10

10 ft Harness Extension



PT8603-20

20 ft Harness Extension



PT8603-30

30 ft Harness Extension

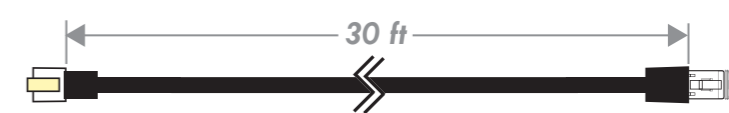

PT8604

Connects to LED Light Sticks (E-7224AB-6) & LED Beacons (E-723AB-6)

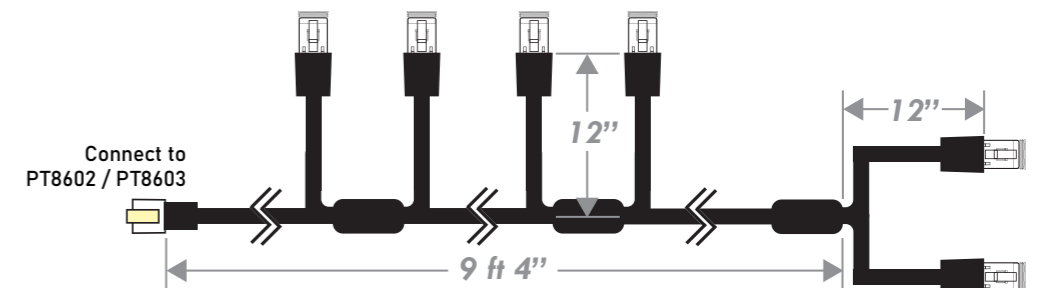

F-S9810

Fuse/Switch Kit



SWP4300
Switch Panel
w/ Pilot Lights

For 12V



ST100 (x3)
ON/OFF Toggle Switch



ST108 (x1)
OFF/MomON Toggle Switch



ATM10
10 AMP Fuse



ATMF14C
Fuse Holder

F-S9820

Fuse/Switch Kit



SWP4100
Switch Panel

For 12V - 24V



ST100 (x3)
ON/OFF Toggle Switch



ST108 (x1)
OFF/MomON Toggle Switch



ATM10
10 AMP Fuse



ATMF14C
Fuse Holder

LED WARNING LIGHTS

LED Headlamp
(See page 2)



LED Warning Light Bar
(See page 7, 8, 12)



LED Beacon Light
(See pages 7-8, 13)



5" Round LED Warning Light
(See page 14)



LED Directional Warning Light
(See page 7, 8, 14)



LED Directional Warning Light
(See page 7, 8, 14)



LED Specialty Lights
(See page 11)



LED Work Light
(See page 9-11)

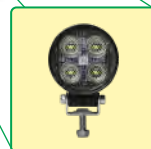

LED WARNING LIGHTS

E-71/72 Series LED Warning Lights

3-IN-1 Each light can be used as **Amber ONLY** or **Blue ONLY** or **ALTERNATING Amber-Blue**

Synchronizable

Colour selection via wires - easy to change colour modes from amber only or blue only to amber | blue alternating.

E-71/72 Beacons, Light Bars & Directional Lights Features:

- 4 Flash Patterns per Colour Setting
- LED Colours: Amber Only, Blue Only Amber|Blue Alternating
- Maximum 8 units of E-72 Series lights can be synchronized in one group

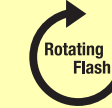

E-728AB
16 x 1W LED
6.75" H x 6.5" Base Dia.
Surface or Pole Mount (1" NPT)
12V - 24V EMC



E-723AB
16 x 1W LED
3.38" H x 6.63" Base Dia.
Surface Mount
12V - 24V EMC



E-725AB
18 x 1W LED
6" L x 1.38" W x 1.25" H
Surface Mount
12V - 24V EMC



E-7211AB
72 x 1W LED
11" L x 6.75" W x 2.5" H
Surface Mount
12V - 24V EMC



E-7117AB
108 x 1W LED
17.5" L x 7.25" W x 2.62" H
Surface Mount
12V - 24V EMC

E-71/72 Light Bars for Snowplow Features:

- LED Amber | Blue Warning Light Stick
- Synchronizable with E-71/72 Series Beacon & Light Bars
- Blue modules to flash & amber modules to stay on



E-7224AB
2x Amber Module || 2x Blue Module
25" L x 1.5" H x 2" D
Bottom or Rear mount
12V - 24V EMC



LED WARNING LIGHTS

Each light can be used as **Amber ONLY** or **Blue ONLY** or **ALTERNATING Amber-Blue**

3-IN-1



Synchronizable

E-76 Series Synchronizable LED Warning Lights

Features:

- 5 Flash Patterns per Colour Setting
- LED Colours: Amber Only; Blue Only; Amber|Blue Alternating
- E-765AB, E-7615AB and E-763AB are all synchronizable

Colour selection via wires - easy to change colour modes from amber only or blue only to amber | blue alternating.

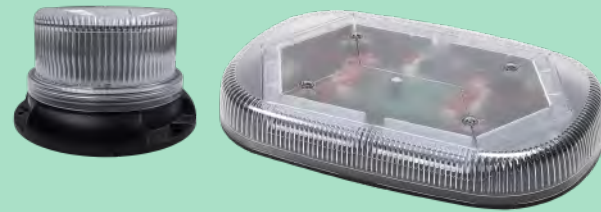

E-765AB

12 x 1W LED
5.3" L x 1.25" W x 0.56" H
Surface Mount
12V - 24V EMC



E-7615AB

64 x 1W LED
15" L x 9.5" W x 2" H
Surface Mount
12V - 30V EMC



E-763AB

24 x 3W LED
3.88" H x 6.5" Base Dia.
Surface Mount
12V - 24V EMC

E-73 Series Synchronizable LED Warning Lights

Features:

- Colour Selection via Flash Pattern Selection
- 17 Flash Patterns: 7 Dual Colour Alternating & 5 each Single Colour
- LED Colours: Amber Only; Blue Only; Amber|Blue Alternating
- E-735AB, E-7315AB and E-736AB are all synchronizable



E-735AB

12 x 1W LED
5.31" L x 1.25" W x 0.56" D
Surface Mount
12V - 24V EMC



E-7315AB

64 x 1W LED
15" L x 9.5" W x 2" H
Surface Mount
12V - 24V EMC



E-736AB

24 x 3W LED
6.5" H x 6.5" Base Dia.
Surface or Pole Mount (1" NPT)
12V - 24V EMC

LED WORK LIGHTS

Ultra Series Square LED Flood Lamps

Features Electronic Thermal Management to prevent light from overheating.



LW3029

3,600 Lumens
4 x 6W
325ft Penetration
2.75" W x 2.75" H x 1.5" D

12V - 30V EMC
IP67 & IP69K RoHS



LW4029-5

8,100 Lumens
9 x 6W
450ft Penetration
4" W x 4.5" H x 1.75" D

10V - 30V EMC
IP67 & IP69K RoHS

Square LED Flood Lamps



LW1332

2,800 Lumens
25W COB
350ft Penetration
3.5"W x 3.5"H x 2.75"D

12V - 30V EMC
CISPR25 Class 3
IP67 & IP69K RoHS



LW1542

4,200 Lumens
35W COB
425ft Penetration
4.75"W x 4"H x 3"D

12V - 30V EMC
CISPR25 Class 3
IP67 & IP69K RoHS

LW4422H

5,400 Lumens
36 x 1.2W LED
650 ft Penetration
4.75"W x 4"H x 2.5"D

9V - 36V EMC
CISPR25 Class 5
IP68 & IP69K RoHS



Features:

- Electronic Thermal Management to prevent light from overheating.
- Adjustable shock absorbing stainless steel mount.
- Built-In Deutsch Connector



All lights on this page are for off-road use.

LED WORK LIGHT

Ultra Series Round LED Flood Lamps

Features Electronic Thermal Management to prevent light from overheating.



LW3229
3,600 Lumens
4 x 6W
325ft Penetration
3" Dia. x 1.5" D
12V - 30V EMC
IP67 & IP69K RoHS



LW4229-5
8,100 Lumens
9 x 6W
450ft Penetration
4.25" Dia. x 1.75" D
10V - 30V EMC
IP67 & IP69K RoHS

Round LED Flood Lamps



LW4322
1,980 Lumens
15 x 1.5W
480 ft Penetration
4.5" Dia. x 5" H x 1.86" D
12V - 30V EMC
IP67 & IP69K RoHS



LW4222
1,755 Lumens
9 x 1.5W
500 ft Penetration
4.25" Dia. x 4.86" H x 1.63" D
10V - 30V EMC
IP67 & IP69K RoHS

Rectangle LED Flood Lamps



LW5032
5,600 Lumens
6 X 10W
500 ft Penetration
5.38" W x 2.64" D x 3.5" H
9V - 36V EMC
CISPR25 Class 5
IP69K RoHS

Features:

- Curved Lens for a wider light spread
- Electronic Thermal Management to control lamp temperature
- Built-In Deutsch Connectors (both female & male mating connectors)

All lights on this page are for off-road use.

LED WORK LIGHT

Speciality LED Lights

Amber/White Flood



LW4342AW
9 x 3W
4.38" W x 5.5" H x 2.5" D
10V - 60V
CISPR25 Class 3
IP69K

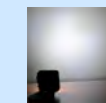

White Flood
• 2,160 Lumens
• 370ft Penetration

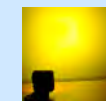

Amber Flood
• 2,100 Lumens
• 310ft Penetration

White Flood/Amber Flashing



LW6097AW
2800 Lumens
9 x 1.5W + 9 x 1W
330 ft Penetration
6.5" W x 1.75" H x 2.5" D
12V - 30V EMC
IP67 & IP69K RoHS

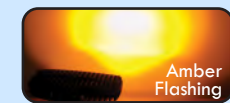
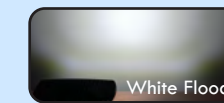

White/Amber/Green Flood



6 x 3W LED
6.5" W x 1.75" H x 2.5" D
12V - 30V
IP67 & IP69K

| Part No. | Description |
|----------|--|
| LW6008 | 1,260 Lumens White LED 450ft Penetration EMC RoHS |
| LW6008-G | 900 Lumens Green LED 350ft Penetration |
| LW6008-A | 1,260 Lumens Amber LED 300ft Penetration |

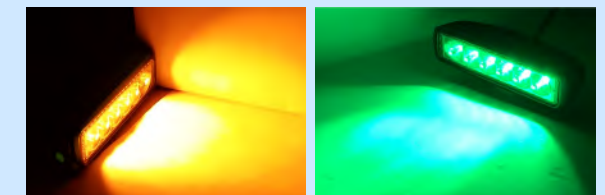

14" L

24 x 3W LED
14" L x 3.19" H x 2.69" D
12V - 30V
IP69K

| Part No. | Description |
|----------|--|
| LW91339A | 3,840 Lumens Amber LED 1,600ft Penetration |
| LW91339G | 4,490 Lumens Green LED 1,200ft Penetration |

22" L

40 x 3W LED
22" L x 3.19" H x 2.69" D
12V - 30V
IP69K

| Part No. | Description |
|----------|--|
| LW92139A | 6,400 Lumens Amber LED 1,990ft Penetration |
| LW92139G | 7,480 Lumens Green LED 1,800ft Penetration |

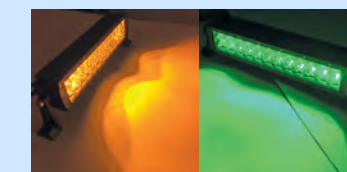

All lights on this page are for off-road use.

LED WARNING LIGHTS

11" LED Warning Light Bar



7 Flash Patterns
 24 x 3W LED
 Clear Lens
 Polycarbonate Base & Lens
 11" L x 6.5" W x 2.4" H
IPX5 EMC
 12V - 30V

E-2011ABM
Amber-Blue



E-2011ACM
Amber-Amber



Magnetic Mount

16" LED Warning Light Bars



E-2161ABM
Magnetic Mount
Amber - Blue



E-2161AB
Bracket Mount
Amber - Blue



19 Flash Patterns
 18 x 1W LED
 Polycarbonate Base & Lens
 16.5" L x 6.5" W x 3" H
12V IPX4K EMC



E-2161AM
Magnetic Mount



E-2161A
Bracket Mount

Amber Lens / Amber LED



LED BEACON LIGHTS



E-890A
Amber



E-890B



6 Flash Patterns

(24 x 1W) + (48 x 0.5W) LED
 8" H x 8.5" Base Dia.
 Surface Mount

12V - 36V EMC



HEAVY DUTY



E-554B
Blue



Hexad Flash

8 x 2W LED
 5" H x 6.5" Base Dia.
 Surface Mount

12V - 40V

6 Flash Patterns

8 x 3W LED
 Amber
 5" H x 6.5" Base Dia.

12V - 24V

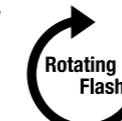

E-556AM
Cigarette Adaptor w/
ON-OFF Switch &
Pattern Selection
(11.8ft wire)

Flash Pattern button
 ON/OFF button



E-556AM
Surface Mount

Rotating, Quad & Quint Flashes

32 LEDs
 3.75" H x 5" Base Dia.

9V - 30V

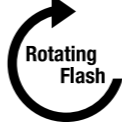

E-333A
Amber
Permanent Mount



E-333AM
Amber
Magnetic Mount



E-333BM
Blue
Magnetic Mount

Rotating Flash (Battery Operated)

20 LEDs
 Magnetic Mount
 4.5" H x 5" Base Dia.

Use 4 AA Batteries (Not Included)

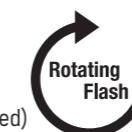

E-480AM
Amber



E-480BM
Blue



ON/OFF Switch

LED WARNING LIGHTS

LED Directional Warning Lights

23 Flash Patterns

6 LED
5" L x 1.25" W x 0.25" H
Surface Mount
12V - 24V IP67



E-916AA
Amber/Amber
SAE Class 1



E-916BB
Blue/Blue
SAE Class 1

E-916AB
Amber/Blue

19 Flash Patterns

6 LED
5" L x 1" W x 0.69" H
Surface Mount
12V - 24V EMC IP67



E-915AA
Amber/Amber
SAE Class 1

E-915BB
Blue/Blue
SAE Class 1

Par 36 (5") LED Warning Lights

Amber or Blue Quad Flash LED Warning Light in Synthetic Resin Rubber-Like Housing

Quad Flash

24 LED
5" Dia. x 6" H x 3" D
9V - 36V EMC

EH-940A
Bracket Mount



EHM-940A
Magnetic Mount



EH-940B
Bracket Mount



EHM-940B
Magnetic Mount

Bracket Mount LED Warning Lights



E-920B-KM
Blue



E-920A-KM
Amber



E-940B-KM
Blue



E-940A-KM
Amber

Quad Flash

24 LED
9V - 36V EMC

Comes with Right Angle Bracket



RUBBER HOUSING LIGHTS

LED Stop / Turn / Tail Lamp in Par 36 (5") Rubber Housing



AXL4000-10R

10 Diodes
5" Dia. x 6" H x 3" D
SAE S2T216
12V



AXL4000-24R

24 Diodes
5" Dia. x 6" H x 3" D
SAE STI
12V



AXL4000M-10R

10 Diodes
5" Dia. x 6" H x 3" D
SAE S2T216
12V - 24V

MULTI-VOLTAGE
12V - 24V

Par 46 (6") Snow Plow Lamps

Coloured 4419 Sealed Beam Lamps in Synthetic Resin Rubber-Like Housing

Each colour comes in Open Wire or with Waterproof Connector



AX4419A
Amber 4419

AX4419A-GM
Amber 4419 +
Waterproof Connector



AX4419BU
Blue 4419

AX4419BU-GM
Blue 4419 +
Waterproof Connector



AX4419R
Red 4419

AX4419R-GM
Red 4419 +
Waterproof Connector

35 Watts
6" Dia. x 7.25" H x 4" D
12V

Waterproof Connector



Strobe Lights



C-883AC
Amber



Double/Quad Flash

17 Joules
8" H x 8.5" Base Dia.
Surface Mount
Aluminum Base
12V - 24V EMC



C-330A
Amber
Surface Mount

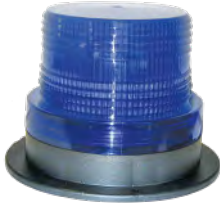

C-330B
Blue
Surface Mount



C-330AM
Amber
Magnetic Mount

C-330BM
Blue
Magnetic Mount

Single Flash

2 Joules
4" H x 5" Base Dia.
12V - 120V DC EMC